

viasit[®]

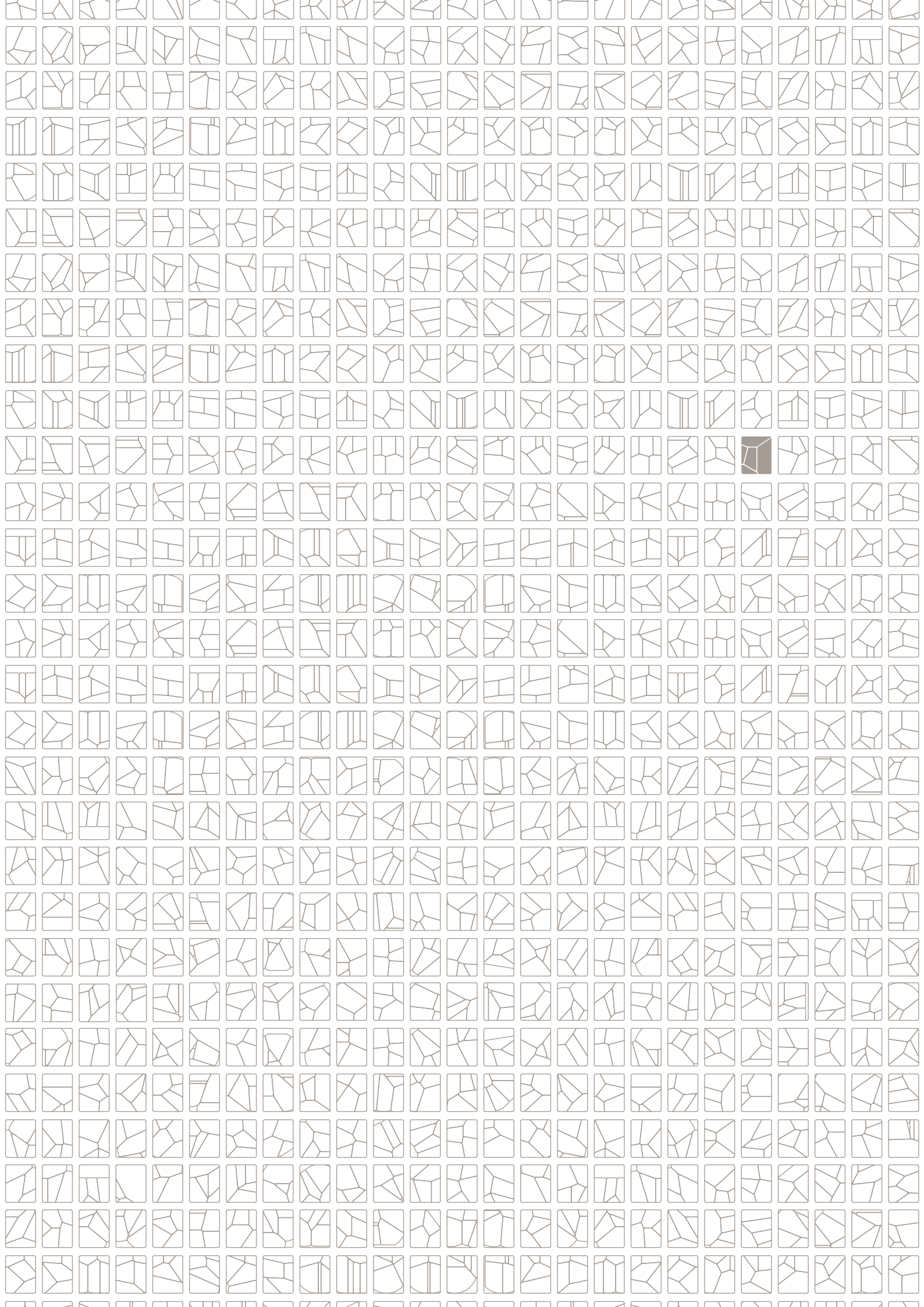

Collection **organic office**



organic office

Design: PALMA KUNKEL
ARCHITEKTUR + DESIGN
Carsten Feil

organic office ist Office Lounge System, ist ein modulares Werkzeug der persönlichen Kommunikation, ist wandelbar, anpassungsfähig und repräsentativ, ist nachhaltig produziert, lässt sich individuell mit der organic office-App konfigurieren.

organic office is an open space system, is a modular communication tool, is convertible, adaptable and versatile, is sustainable, can be individually configured using the organic office-app.

organic office est un système d'aménagement lounge pour bureau, est un outil constitué de modules pour la communication en face-à-face, est modulable, adaptable, représentatif, est issu d'une production durable, permet une configuration individualisée grâce à l'application organic office.

organic office is een office lounge systeem, is een modulair meubel voor persoonlijke communicatie, is flexibel, aanpasbaar en representatief, is duurzaam geproduceerd, kan individueel met de organic office-app worden geconfigureerd.



5 Module - unzählige Kombinationen

5 elements - endless combinations | 5 modules - d'innombrables
combinaisons | 5 modules - oneindig veel combinaties

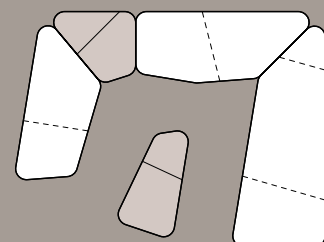
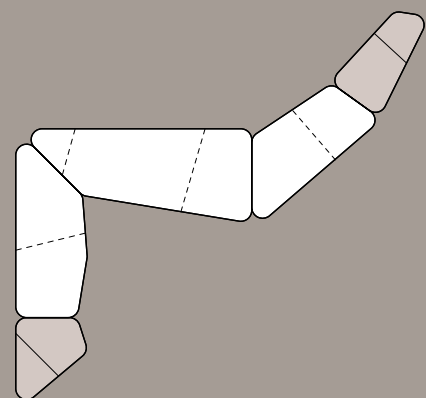
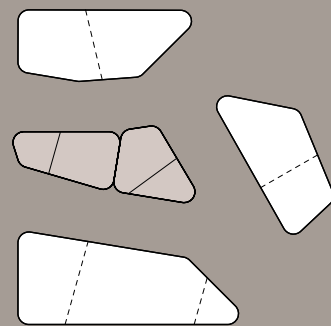
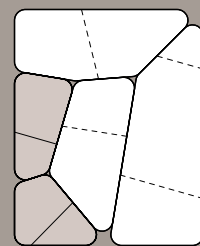
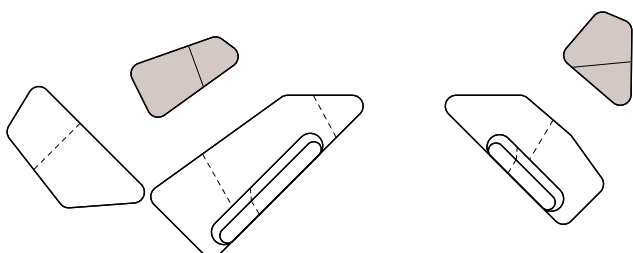
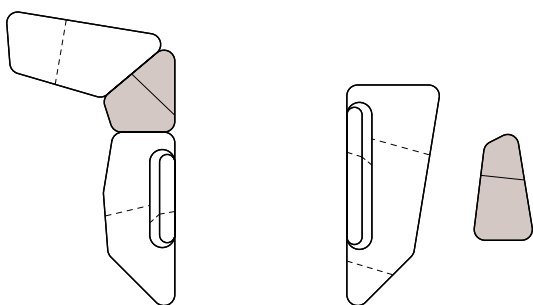
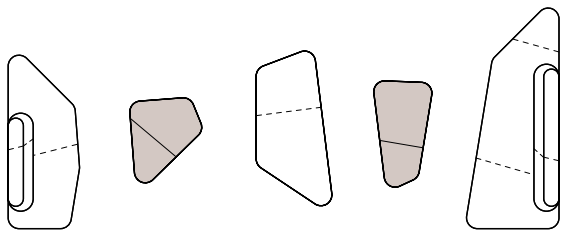
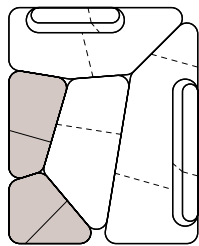

Mobil, vielseitig, anpassungsfähig

Mobile, versatile, adaptable | Mobile, polyvalent, adaptable |

Mobiel, veelzijdig, aanpasbaar

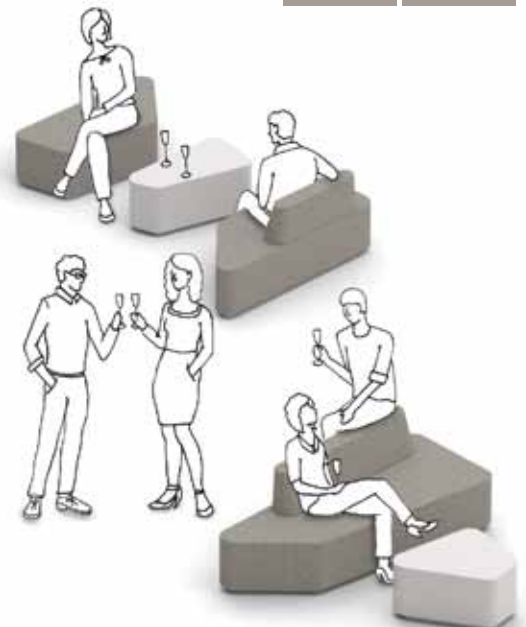
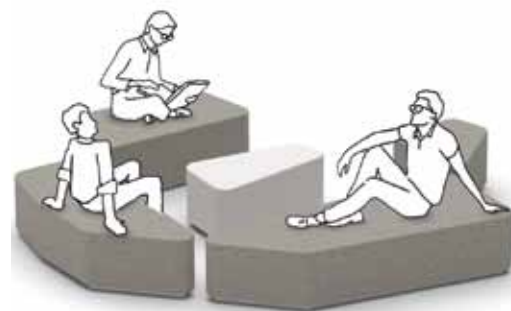
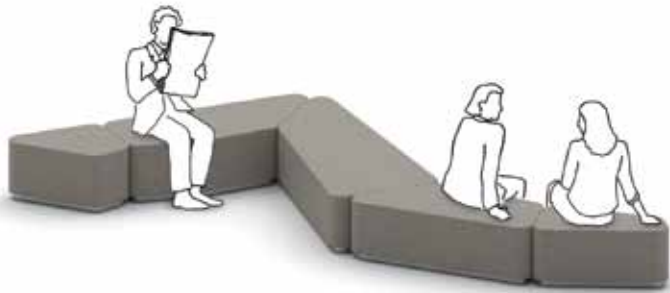



Office Lounge System - organic office schafft eine ruhige Warte-Atmosphäre und kann nach Bedarf und Raumangebot vergrößert oder verkleinert werden.

Open space system - organic office creates calm within your environment and can be expanded or contracted according to requirements and space.

Système Lounge - organic office crée une ambiance reposante pour les moments d'attente et peut être adapté selon les besoins et la place disponible.

Lounge system - organic office creëert een rustige relax-modus en kan naar behoefte en ruimteaanbod worden vergroot of verkleind.

Creative Workshop - organic office lädt ein zum Teamtreffen. Mit organic office können Gruppen ihre eigene temporär genau passende Arbeitsanordnung finden und wieder verändern.

Creative Workshop - organic office delivers a creative meeting environment and user groups can find their own temporary perfect working layout and then change it as desired.

Atelier Créatif - organic office favorise le travail en équipe. Avec organic office, les groupes de travail peuvent trouver une configuration temporaire de travail et la modifier au gré des besoins.

Creative workshop - organic office nodigt uit om elkaar te ontmoeten. Met organic office kunnen groepen tijdelijk hun eigen, perfect passende werkruimte indelen en zo nodig wijzigen.

Business Club - Pause im Büro. Es braucht Raum für Mitarbeiter als Treffpunkt. Oder auch einen Ort zum Weiterdenken. organic office bietet viele Varianten der Nutzung, die dem Erfolg des Unternehmens ganz unterschiedlich dienen können.

Business Club - Take a break in the office. organic office provides the space for employees to meet, link, think and relax. organic office provides convertible use that can contribute to corporate success in totally different ways.

Business Club - La pause au bureau. Les collaborateurs ont besoin d'un espace pour se rencontrer, d'un lieu pour continuer à cogiter. organic office offre de nombreuses combinaisons, qui peuvent contribuer au succès de l'entreprise de manière totalement différente.

Businessclub - Pauze op kantoor. Er is een ruimte nodig als informele ontmoetingsplaats voor de medewerkers. Of ook een plaats om te communiceren. organic office biedt vele gebruiksvarianten, die allemaal op hun eigen wijze kunnen bijdragen tot het succes van de onderneming.

organic office-App

organic office-app | application

organic office | organic office-app

Mit der **organic office-App** können Nutzer die unterschiedlichen Anordnungen und Materialkombinationen individuell auswählen, sich ein Ergebnis 3D anschauen und eine Anfrage an **viasit** senden.

The **organic office-app** allows users the opportunity to individually select different layouts, combinations, elements, materials and finishes, to view the result in 3D and send an enquiry to **viasit**.

Avec l'**application organic office**, les utilisateurs peuvent choisir les différents agencements et combinaisons de matériaux de façon individualisée, visualiser le résultat en 3D et envoyer une demande d'offre à **viasit**.

Met de **organic office-app** kunnen gebruikers de verschillende configuraties en materiaalcombinaties individueel kiezen, een 3D-resultaat bekijken en een aanvraag versturen aan **viasit**.

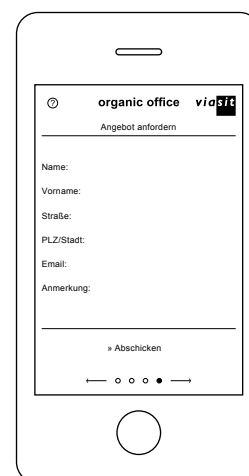
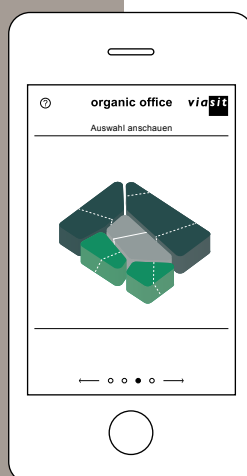
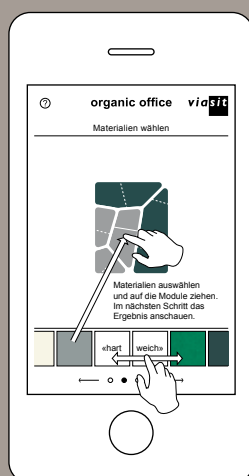
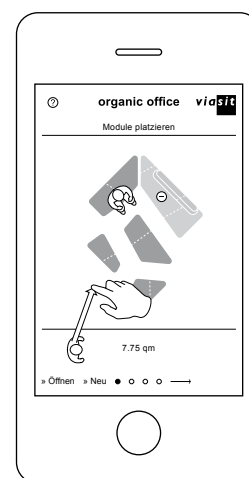
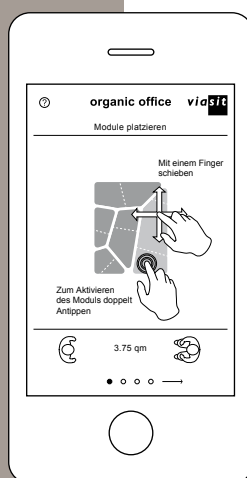



Die Übersicht

Overview

Synoptique

Het overzicht

organic office gibt es als Set bestehend aus fünf gepolsterten Modulen. Die zwei großen Polstermodule können zusätzlich mit einer Rückenlehne ausgestattet werden. Wahlweise sind die drei kleinen Module auch mit einer harten, lackierten Oberfläche erhältlich. Alle Elemente haben einen silber pulverbeschichteten Sockel.

organic office is available as a 5 element set. The two large upholstered elements can be fitted with an optional backrest. The three smaller elements are also available with a hard, lacquered surface for use as a table or worksurface. All elements have a silver powder-coated steel base frame.

organic office existe sous la forme d'un kit composé de cinq modules rembourrés. Les deux grands éléments rembourrés peuvent être équipés d'un dossier supplémentaire. Les trois petits modules sont également disponibles au choix avec une surface en dur et laquée. Tous les éléments ont un socle coloris finition epoxy argent.

organic office bestaat als set uit vijf gestoffeerde modules. De twee grote kussenelementen kunnen bijkomend met een rugleuning worden uitgerust. Naar keuze zijn de drie kleine modules ook met een hard, gelakt oppervlak te verkrijgen. Alle elementen hebben een zilver poedergecoate sokkel.



Stromanschluss, optional
connection for power supply, optionally
Prise d'alimentation électrique
Elektriciteit aansluiting, optioneel

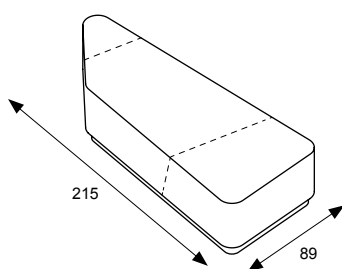
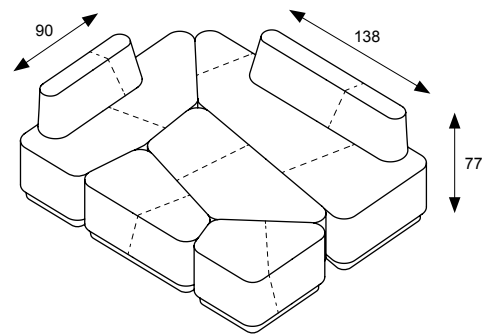
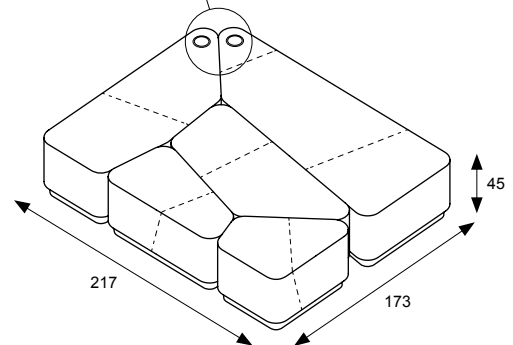

78.1000

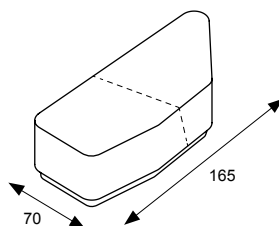

78.2000

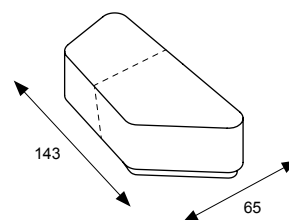

78.3000

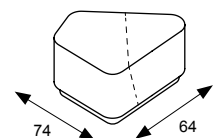

78.4000

Set 5 Polsterelemente

Set of 5 upholstered elements
 Kit de 5 éléments rembourrés
 Set 5 kussenelementen

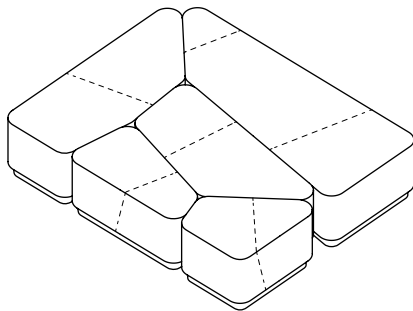

78.1000, 78.2000, 78.3000,
 78.4000, 78.5000

Set mit Rückenlehne

wahlweise 1 oder 2 Rückenlehnen
 Set with backrest, optional with
 1 or 2 backrests
 Kit avec dossier, au choix avec
 1 ou 2 dossiers
 Set met rugleuning, naar keuze
 met 1 of 2 rugleuningen

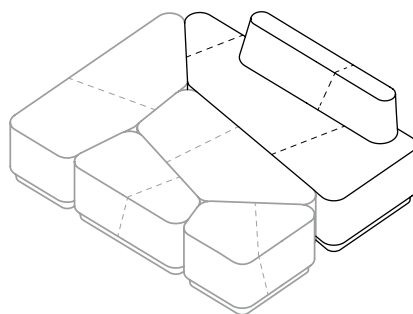

78.1000, RL781, 78.2000,
 78.3000, 78.4000, 78.5000

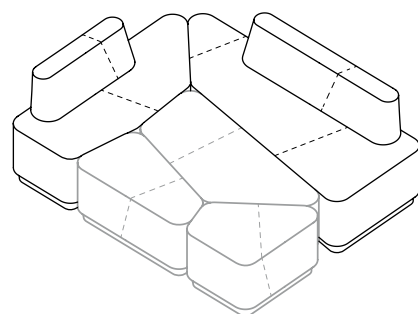

78.1000, RL781, 78.2000, RL782,
 78.3000, 78.4000, 78.5000

Set mit Tischen

wahlweise mit 1, 2 oder 3 Tischen
 Set with table surfaces, optional with
 1, 2 or 3 tables
 Kit avec tables, au choix avec 1, 2
 ou 3 tables
 Set met tafels, naar keuze met 1, 2
 of 3 tafels

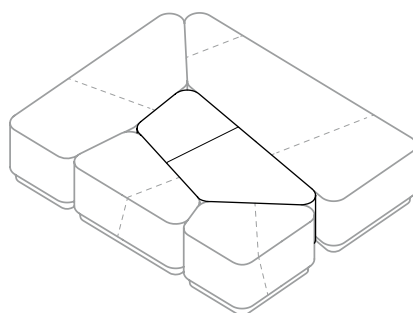

78.1000, 78.2000, 78.3001,
 78.4000, 78.5000

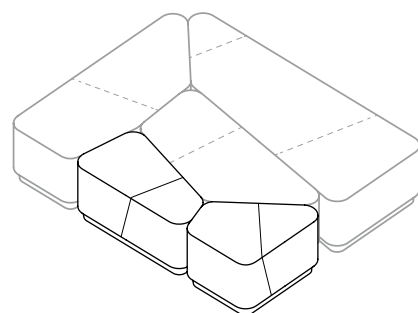

78.1000, 78.2000, 78.3000,
 78.4001, 78.5001

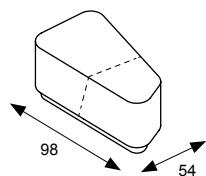

78.5000

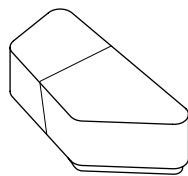

78.3001

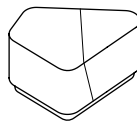

78.4001

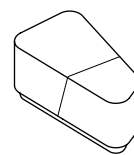

78.5001







Achromatic Collection



Gabriel | Step Melange
50/5315
Tische RAL 7042



Gabriel | Step Melange
50/5314
Tische RAL 7021



Kvadrat | Steelcut Trio 2
80/8190
Tisch RAL 7042

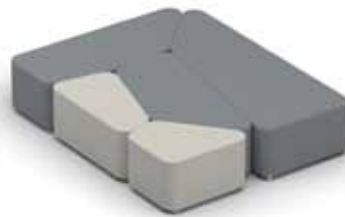

Kvadrat | Steelcut Trio 2
80/8188
Tische RAL 9001



Camira | Blazer
70/7323, 70/7324
Tisch RAL 9001



Kvadrat | Steelcut Trio 2
80/8188
Tische RAL 7021



Fidivi | Laser J Flash
70/7342, 70/7341
Tisch RAL 9001



Gabriel | Step Melange
50/5314
Tische RAL 9001



Camira | Blazer
70/7323

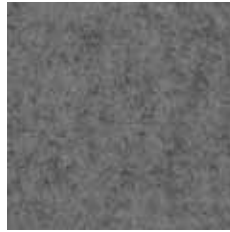

Camira | Blazer
70/7324



Camira | Blazer
70/7325

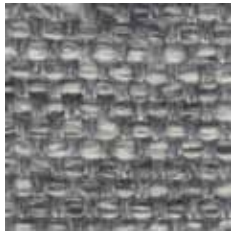

Fidivi | LaserJ Flash
70/7340

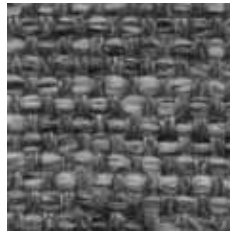

Fidivi | LaserJ Flash
70/7341

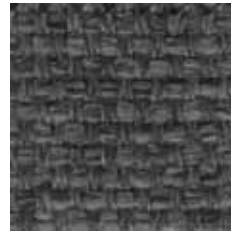

Fidivi | LaserJ Flash
70/7342

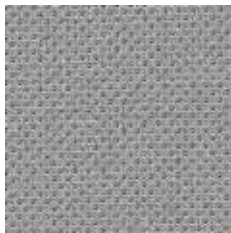

Gabriel | Atlantic
10/1043



Gabriel | Atlantic
10/1046



Gabriel | Atlantic
10/1040

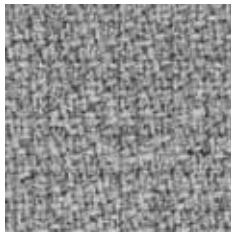

Gabriel | Step Melange
50/5316



Gabriel | Step Melange
50/5315

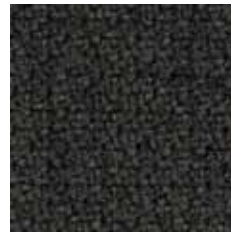

Gabriel | Step Melange
50/5314

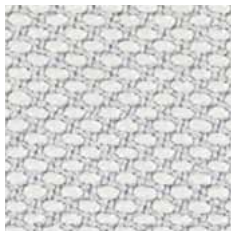

Kvadrat | Steelcut Trio 2
80/8190

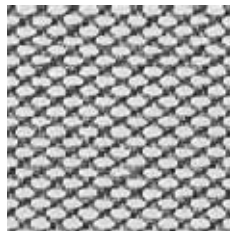

Kvadrat | Steelcut Trio 2
80/8170



Kvadrat | Steelcut Trio 2
80/8188



Fiedler | Leder
60/638

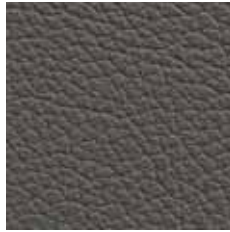

Fiedler | Leder
60/639

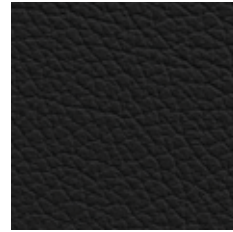

Fiedler | Leder
60/6390

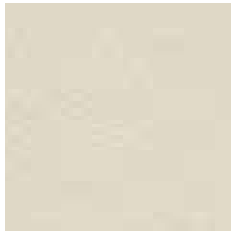

Hornschuch | Skai
70/3080

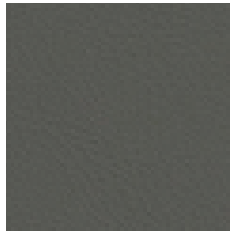

Hornschuch | Skai
70/3082



Hornschuch | Skai
70/3081

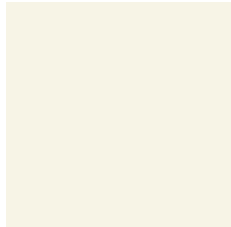

RAL | 9001
Cremeweiss
Creme white
Blanc crème
Creme wit

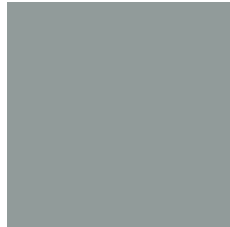

RAL | 7042
Verkehrsgrau A
Traffic grey
Gris signalisation
Verkeersgrijs



RAL | 7021
Schwarzgrau
Dark grey
Gris noir
Zwartgrijs

Folgende Stoffe aus unserer Stoffcollection sind verwendbar:
The following fabrics from our fabric collection can be used:
Les revêtements suivants de notre collection de tissus sont disponibles:
De volgende stoffen uit onze collectie stoffen kunnen worden gebruikt:

Gabriel Atlantic | Step Melange, Camira Blazer, Kvadrat Steelcut Trio 2, Fidivi Laser J Flash, Kunstleder, Leder



Chromatic Collection

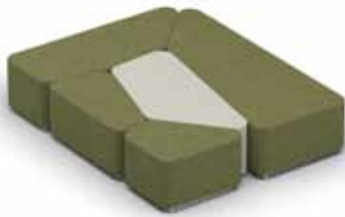

Camira | Blazer
70/7368
Tisch RAL 9001

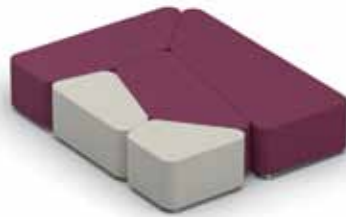

Camira | Blazer
70/7364
Tische RAL 9001

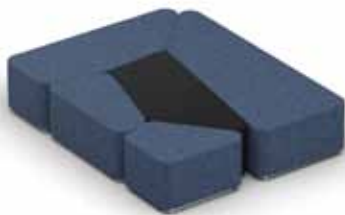

Camira | Blazer
70/7363
Tisch RAL 7021



Camira | Blazer
70/7367
Tische RAL 7042

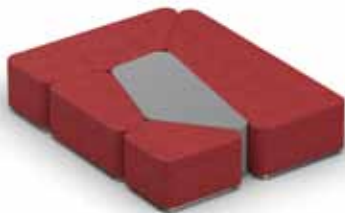

Camira | Blazer
70/7366
Tisch RAL 7042



Camira | Blazer
70/7369
Tische RAL 7042

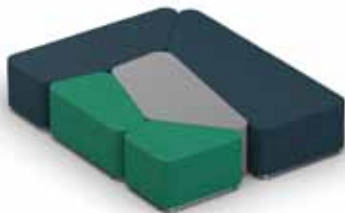

Camira | Blazer
70/7360, 70/7321
Tisch RAL 7042



Camira | Blazer
70/7370, 70/7371
Tische RAL 9001



Camira | Blazer
70/7362



Camira | Blazer
70/7361



Camira | Blazer
70/7360



Camira | Blazer
70/7363

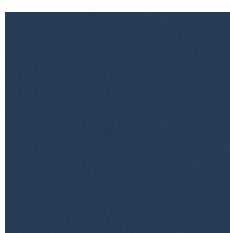

Camira | Blazer
70/7320



Camira | Blazer
70/7321



Camira | Blazer
70/7366



Camira | Blazer
70/7365



Camira | Blazer
70/7364



Camira | Blazer
70/7369



Camira | Blazer
70/7368



Camira | Blazer
70/7367



Camira | Blazer
70/7372



Camira | Blazer
70/7371



Camira | Blazer
70/7370

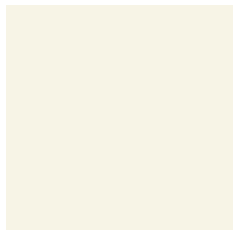

RAL | 9001
Cremeweiss
Creme white
Blanc crème
Creme wit



RAL | 7042
Verkehrsgrau A
Traffic grey
Gris signalisation
Verkeersgrijs



RAL | 7021
Schwarzgrau
Dark grey
Gris noir
Zwartgrijs

Folgende Stoffe aus unserer Stoffcollection sind verwendbar:

The following fabrics from our fabric collection can be used:

Les vêtements suivants de notre collection de tissus sont disponibles:

De volgende stoffen uit onze collectie stoffen kunnen worden gebruikt:

Gabriel Atlantic | Step Melange, Camira Blazer, Kvadrat Steelcut Trio 2, Fidivi Laser J Flash, Kunstleder, Leder



Camira Blazer		
Qualität		70
Nummer		7320, 7321, 7323, 7324, 7325, 7360-7372
Material	Schurwolle, Nicht schwermetallhaltige Farbstoffe	100%
Entflammbarkeit	BS EN 1021 - 1:2006 (Zigarettentest), BS EN 1021 - 2:2006 (Sreichholztest), BS 7176:2007 Low Hazard, BS 5852:2006 Section 4 Ignition Source 5, BS 7176:2007 Medium Hazard Bemerkung: Schwerentflammbarkeit hängt von verwendetem Schaum ab	
Gewicht	g/m ² ±5% (645 g/lfd.M ±5%)	460
Breite	cm nutzbare Breite	140
Lichtechtheit	(ISO 105 - B02:2013)	5
Reibechtheit	Nass/Trocken (ISO 105 - X12:2002)	4/4
Scheuerfestigkeit	Scheuertouren Martindale	50.000



Fidivi Laser J Flash		
Qualität		70
Nummer		7340, 7341, 7342
Material	Polyester Trevira CS	100%
Entflammbarkeit	C1 / CRIB 5 / M1 / B1 / EN 1021/1-2 / BS 7176 Medium Hazard / NF D 60013 Class AM18 / IMO A 652 (16)	
Gewicht	g/m ² ±5% 550 / g/lfd.M ±5% 770 UNI EN 12127	
Breite	cm	140
Lichtechtheit	UNI EN ISO 105 - B02 (Blaumaßstabe) - Xenotest -	6
Reibechtheit	UNI EN ISO 105 - X12 (Graumaßstabe) - Crockmeter -	4/5
Scheuerfestigkeit	Scheuertouren Martindale (ISO 12947-2)	100.000



Gabriel Atlantic		
Qualität		10
Nummer		1040, 1043, 1046
Material	Polyester	100%
Entflammbarkeit	Calif. Bull. 117E, BS EN 1021 1&2, Önorm B 3825 B1, 3800-Q1 UK, UNI 9175 Class 1 I EMME, NFP 92-503:M3, AM 18 – NF D 60-013, Erfüllt auch andere Feuertests, Schwerentflammbarkeit hängt von verwendetem Schaum und der schwerentflammbaren Ausrüstung ab	
Gewicht	pro. lf. Meter ca. Gramm	530
Breite	cm	150
Lichtechtheit	Skala 1-8, max. 8 - EN ISO 105-B02	5-7
Reibechtheit	Skala 1-5, max. 5 - EN ISO 105x12 (nass/trocken)	4-5/4-5
Scheuerfestigkeit	Scheuertouren Martindale (ISO 12947-2)	110.000



Gabriel Step Melange		
Qualität		50
Nummer		5314 - 5316
Material	Trevira CS	100%
Entflammbarkeit	Calif. Bull. 117E, IMO A.652 (16), MED Certificate IMO, DIN 4102:B1, NFP 92-503:M1, BS EN 1021 1&2, BS 5852 Part 1 0,1 Cigarette & match, BS 5852, Crib 5 UNI 9175 Class 1 I EMME, Önorm B 3825 B1 3800-Q1 UK, FAR/JAR 25.853(a)(i)(ii), erfüllt auch andere Feuertests, Schwerentflammbarkeit hängt von verwendetem Schaum und der schwerentflammbaren Ausrüstung ab, BS 7176 Medium Hazard, AM 18 - NF D 60-013, CA TB 117-2013, UNI 9175 Class 1 I EMME	
Gewicht	pro. lf. Meter ca. Gramm	470
Breite	cm	140
Lichtechtheit	Skala 1-8, max. 8 - EN ISO 105 - B02	5-7
Reibechtheit	Skala 1-5, max. 5 - EN ISO 105x12 (nass / trocken)	4-5
Scheuerfestigkeit	Scheuertouren Martindale (ISO 12947 - 2)	100.000



Kvadrat Steelcut Trio 2		
Qualität		80
Nummer		8170, 8188, 8190
Material	Schurwolle, Kammgarn Nylon	90 % 10 %
Entflammbarkeit	EN 1021-1/2 Ignition Source 0-1, BS 5852 Ignition Source 2-3, DIN 4102 B2, ÖNORM B1 / Q1, NF D 60 013, UNI 9175 1IM, US Cal. Tech. Bull. 117, IMO A.652(16), Schwerentflammbarkeit hängt von verwendetem Schaum ab	
Gewicht	g/ lfd. m	770
Breite	ca. cm	140
Lichtechtheit	ISO 105 - B02	5-7
Reibechtheit	ISO 105 - X12 (nass/trocken)	4/4-5
Scheuerfestigkeit	Scheuertouren Martindale (ISO 12947-2)	100.000

Hornschuch Skai		
Qualität		70
Nummer		3080, 3081, 3082
Material	PU-Finish PVC-Compound BW-Gewebe	ca. 2% ca. 73% ca. 25%
Entflammbarkeit	BS5852 IS 0+1, EN1021-1+2, MVSS 302/ISO 3795/DIN 75200/ Richtline 95/28/EG	
Gewicht	ca. g/m ²	780
Breite	ca. cm	150
Lichtechtheit	DIN EN ISO 105-B02	5
Reibechtheit	DIN EN ISO 105-X12 (nass / trocken)	4,5/4,5
Scheuerfestigkeit	Scheuertouren Martindale	50.0000

Fiedler Leder		
Qualität		60
Nummer		638, 639, 6390
Material	Im Fass durchgefärbtes, korrigiertes mit feinem Narben geprägtes Nappa Leder mit aller höchsten Gebrauchseigenschaften. Stärke 1,0/1,2 mm	
Brenntest, Zigarettenbrenntest	Brandschutz: nach Test bestanden: BS 5852: 1990 section 5 ignition source crij 5, NFD 60013, Schwer entflammbar nach DIN 75200 und DIN EN ISO 1021 Teil I + II. OBJEKT ist Säure- und Laugenbeständig ausgerüstet (EN-ISO 105-E04) OBJEKT ist zusätzlich hydrophobiert	B=0
Reißfestigkeit	ISO 3377-1	>20
Lichtechtheit	ISO 105 B02	>5
Reibechtheit	Veslic (Graumaßstab Stufe 1-5) trocken 500 Touren / nass 250 Touren / Schweiß 80 Touren pH 9 (DIN EN ISO 11640)	>5 / >4 / >4
Dauerfaltverhalten	ISO 5402 (nach 20.000 Knickungen)	keine Risse

Eventuelle Farb- und Strukturabweichungen zwischen den Originalmaterialien und den abgebildeten Mustern sind drucktechnisch bedingt und können daher nicht als Reklamationsgrund anerkannt werden.

Any differences in colour texture which may occur between the original materials and the illustrated samples are due to the printed reproduction and cannot, therefore, be accepted as cause for complaint.

Les éventuelles différences de couleurs entre les matériaux réels et les photos des catalogues sont dues aux techniques d'impression et ne peuvent donc pas faire l'objet de réclamations.

Eventuele kleur en stukturaafwijkingen tussen de originele materialen en de afgebeelde kleurstenen is mogelijk drucktechnisch overmijdbaar en kunnen daarom niet als gereclameerd behandeld worden.



viasit Bürositzmöbel GmbH

Boxbergweg 4

D - 66538 Neunkirchen

Tel. +49 (0) 6821 / 2908-0

Fax +49 (0) 6821 / 2908-290

info@viasit.com

www.viasit.com

Geschäftsführer:

Thomas Schmeer

Werner Schmeer

AG: Saarbrücken

HRB 91731

Sitz: Neunkirchen

Stand: Januar 2015



organic office Design
PALMA KUNKEL
ARCHITEKTUR + DESIGN
Carsten Feil

